

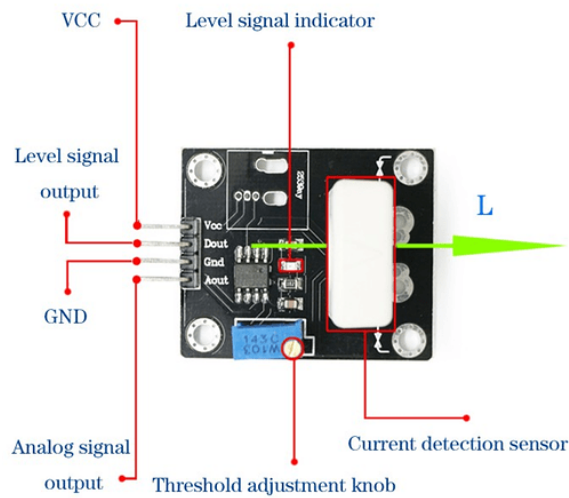

## Pinouts:

Pin Name	Type	Description
VCC	Power	Module power supply, 3-12V DC.
GND	Ground	Ground reference for the module.
Aout	Analog Output	Provides a voltage proportional to the measured current.
Dout	Digital Output	Provides a TTL-level signal when an overcurrent is detected.



## Product Pictures:

